

## Major/Blues

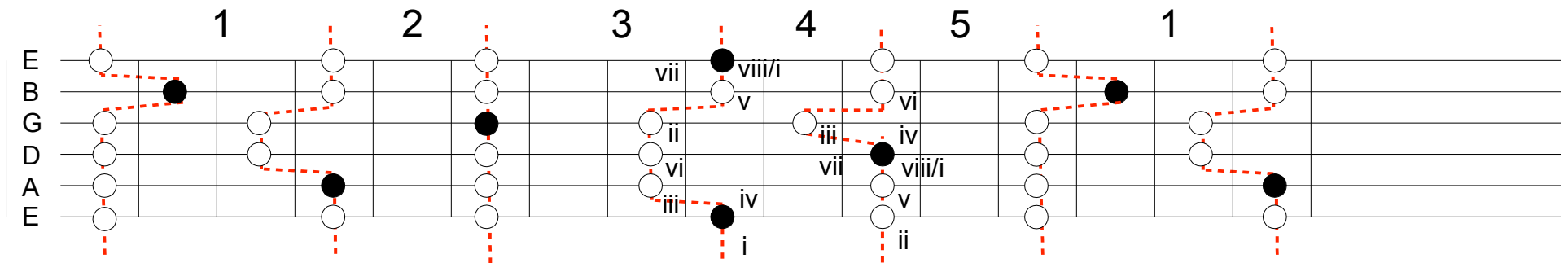

● Tonic = Root = the key of the song

This drawing shows how the 5 pentatonic patterns “fit together” on the neck. The “vertical” dashed red lines show the notes that are shared with the adjoining pattern. The “number” assignment is arbitrary. Gibson's “Learn & Master Guitar Class” uses a different numbering scheme, but the patterns are identical.

The roman numerals (i, ii... ), show the “do ray me fa so la tee do” notes of the Major scale – notice that not all notes from the Major scale are present in the pentatonic. This whole group of patterns can be “slid” up & down the neck until the black notes align to the “key” of the song. So for the key of A, you'd put the “i” on the 5<sup>th</sup> fret of the low-E string – all of the other patterns are then spatially relative to that “E string, 5<sup>th</sup> fret position” on the neck and any note of any of the 5 patterns will “sound good”.